



CML Semiconductor Products

Cordless Telephone Scrambler

FX128

D/128/1 October 1997

Provisional Information

Features

- Full-Duplex Audio Processing
- On-Chip Filters
- Carrier Rejection >55dB
- Uses IF (10.24MHz) Clock
- Requires No Extra Crystal
- Excellent Audio Quality
- Low Power Operation (3.0V)
- ECPA* Qualified Voice Protection
- Battery Powered Portability
- Cordless Telephones and Wireless PBX

Applications

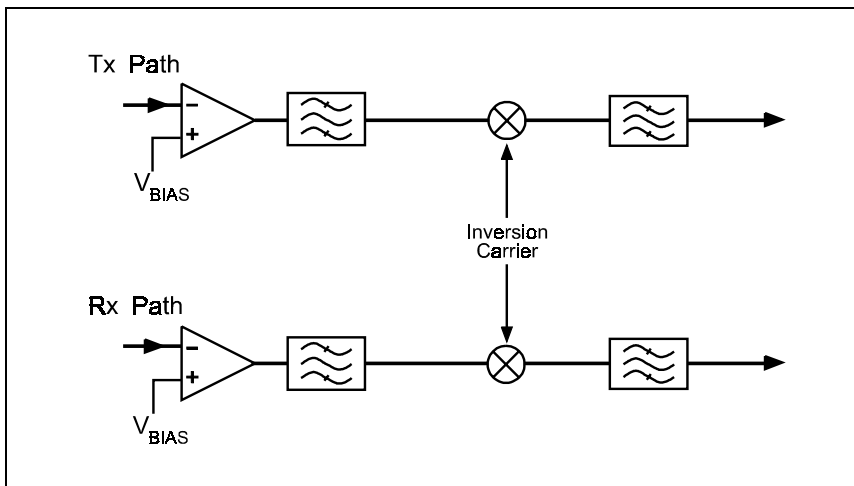

1.1 Brief Description

The FX128 is a full-duplex frequency inversion scrambler designed to provide secure conversations for 46/49 MHz cordless telephone users. The Rx and Tx audio paths consist of the following:

1. A switched-capacitor balanced modulator with high baseband and carrier rejection.
2. A 3.3kHz inversion carrier (injection tone).
3. A 3100Hz lowpass filter.
4. Input op-amps with externally adjustable gain.

The FX128 uses mixed signal CMOS switched-capacitor filter technology and operates from a single supply in the range of 3.0 to 5.5 volts. The inversion carrier's frequency and filter switching clock are generated on-chip using an external 10.24MHz or 3.58/3.6864 MHz crystal or clock input (selectable).

This device is available in 16-pin SOIC (FX128D4) and 16-pin plastic DIL (FX128P3) packages.

*Electronics Communications Privacy Act (Title 18, US Code 2510 etc.).

CONTENTS

<u>Section</u>	<u>Page</u>
1.1 Brief Description	1
1.2 Block Diagram	3
1.3 Signal List	4
1.4 External Components	5
1.5 Application	6
1.6 Application Notes	6
1.7 Performance Specification	7
1.7.1 Electrical Performance	7
1.7.2 Packaging	10

1.2 Block Diagram

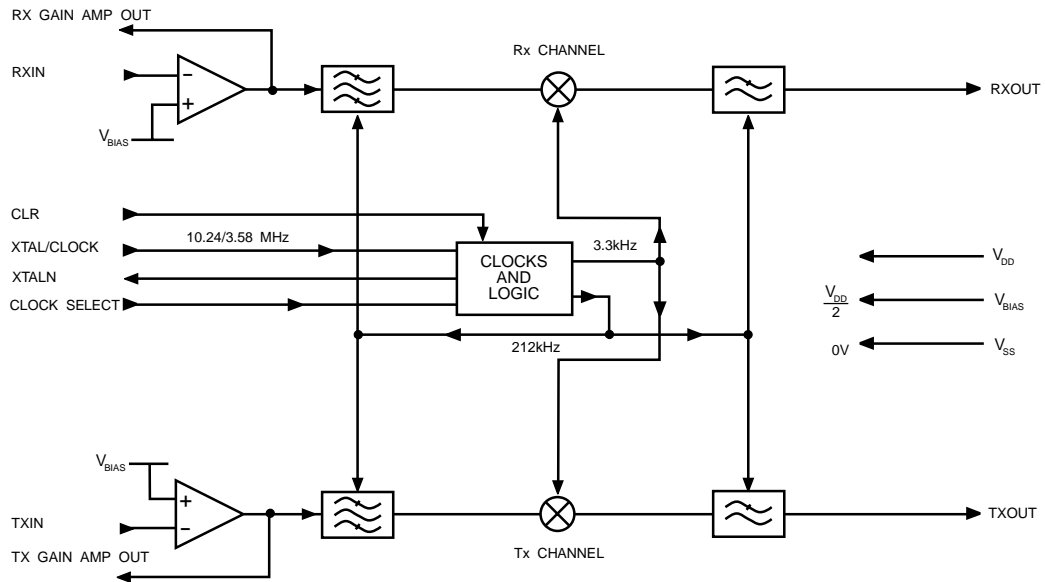

Figure 1 Block Diagram

1.3 Signal List

Package D4/P3	Signal		Description
Pin No.	Name	Type	
1	XTALN	O/P	This is the output of the clock oscillator inverter.
2	XTAL/CLOCK	I/P	10.24MHz or 3.58/3.6864 MHz or an externally derived clock is injected at this pin. See Figure 2.
3	-	N/C	No connection should be made to this pin.
4	TXOUT	O/P	This is the analogue output of the transmit channel. It is internally biased at $V_{DD}/2$.
5	TX GAIN AMP OUT	O/P	This is the output pin of the transmit gain adjusting op-amp. See Figure 3 for gain setting components.
6	TXIN	I/P	This is the analogue signal input to the transmit channel. This input goes to a gain adjusting op-amp whose gain is set by external components. See Figure 3.
7	-	N/C	No connection should be made to this pin.
8	VSS	POWER	Negative supply (GND)
9	VBIAS	O/P	This is an internally generated bias voltage output ($V_{DD}/2$)
10	-	N/C	No connection should be made to this pin.
11	RXIN	I/P	This is the analogue signal input to the receive channel. This input goes to a gain adjusting op-amp whose gain is set by external components. See Figure 3.
12	RX GAIN AMP OUT	O/P	This is the output pin of the receive gain adjusting op-amp. See Figure 3 for gain setting components.
13	RXOUT	O/P	This is the analogue output of the receive channel. It is internally biased at $V_{DD}/2$.
14	CLR	I/P	A logic 1 on this input selects the invert mode. A logic 0 selects the clear (not inverted) mode.
15	CLOCK SELECT	I/P	Selects either 10.24 or 3.58/3.6864 MHz clock frequency. A logic "1" selects 10.24MHz and a logic "0" selects 3.58/3.6864 MHz. This input is internally pulled high.
16	VDD	POWER	Positive supply of 3.0 to 5.5V.

Notes: I/P = Input
O/P = Output
N/C = No Connection

1.4 External Components

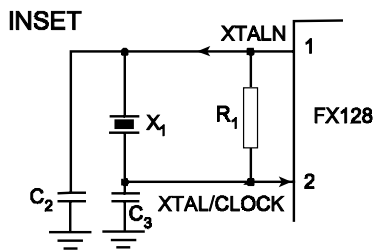
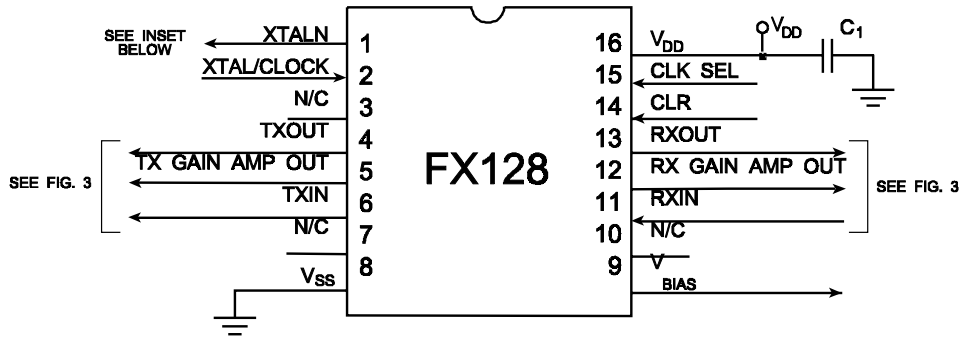

Component	Value	Value
X1	10.24MHz	3.58/3.6864 MHz
R1	1.0MΩ	1.0MΩ
C1	0.47μF	0.47μF
C2	22.0pF	33.0pF
C3	22.0pF	47.0pF

Tolerance: R = ±10% C = ±20%

Note: Xtal circuitry shown is in accordance with CML's Xtal Application Note.

Figure 2 Recommended External Components

1.5 Application

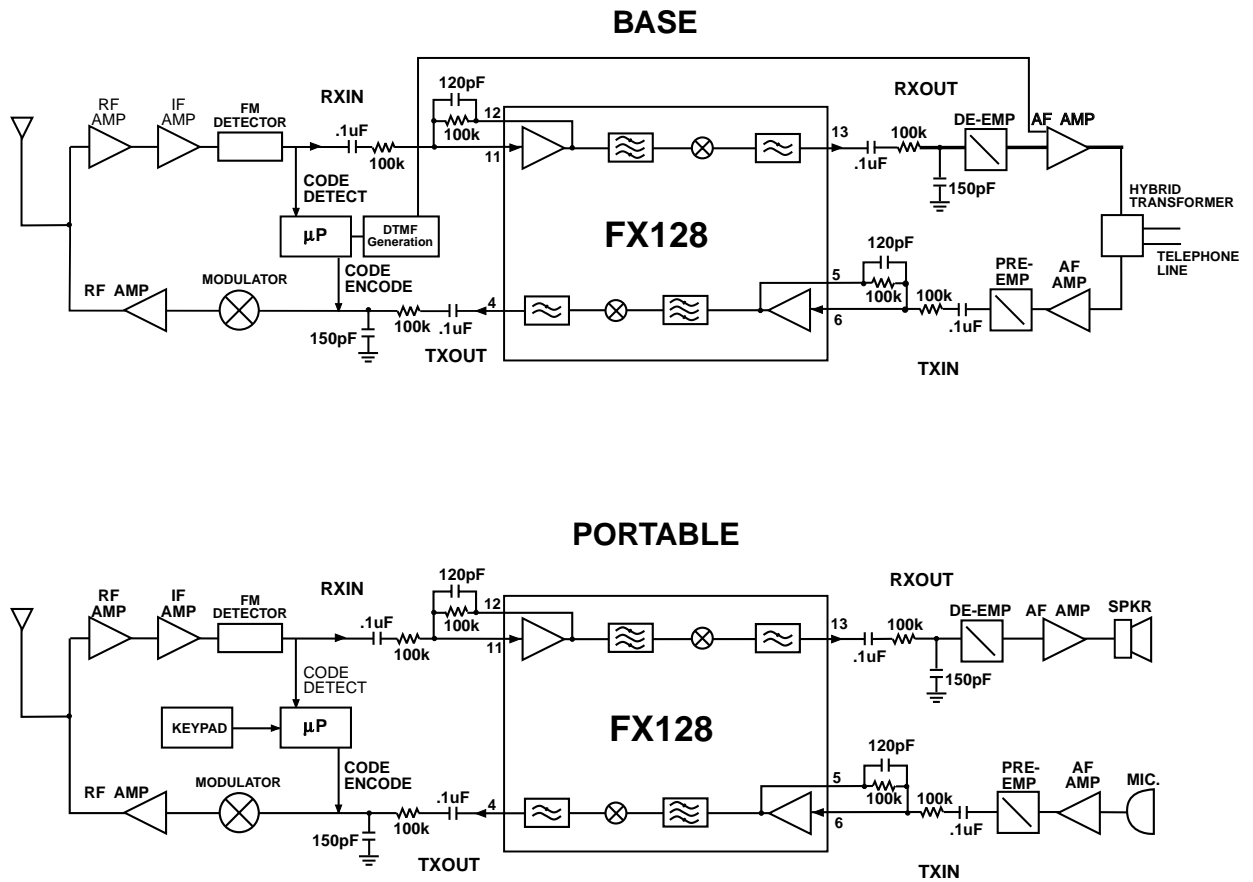

Note: Components shown set a gain of 0dB

Figure 3 Block Diagram of a Typical Application of the FX128 (Cordless Phone)

1.6 Application Notes

Formulae for calculating the carrier frequency, upper cutoff frequency and lower cutoff frequency with clock select pin high are as follows:

$$\begin{aligned}
 \text{Carrier Frequency} &= (3.2995\text{kHz} / 10.24\text{MHz}) * \text{XTAL frequency} \\
 \text{Upper Cutoff Frequency} &= (2.800\text{kHz} / 10.24\text{MHz}) * \text{XTAL frequency} \\
 \text{Lower Cutoff Frequency} &= (400\text{Hz} / 10.24\text{MHz}) * \text{XTAL frequency}
 \end{aligned}$$

Formulae for calculating the carrier frequency, upper cutoff frequency and lower cutoff frequency with clock select pin low are as follows:

$$\begin{aligned}
 \text{Carrier Frequency} &= (3.2995\text{kHz} / 3.415\text{MHz}) * \text{XTAL frequency} \\
 \text{Upper Cutoff Frequency} &= (2.800\text{kHz} / 3.415\text{MHz}) * \text{XTAL frequency} \\
 \text{Lower Cutoff Frequency} &= (400\text{Hz} / 3.415\text{MHz}) * \text{XTAL frequency}
 \end{aligned}$$

1.7 Performance Specification

1.7.1 Electrical Performance

Absolute Maximum Ratings

Exceeding these maximum ratings can result in damage to the device.

General	Min	Max	Units
Supply ($V_{DD} - V_{SS}$)	- 0.3	7.0	V
Voltage on any pin to V_{SS}	-0.3	($V_{DD} + 0.3$)	V
Current in or out of V_{DD} and V_{SS} pins	-30	+30	mA
Current in or out of any other pin	-20	+20	mA
D4 and P3 Packages			
Total Device Dissipation at $T_{amb} = 25^{\circ}\text{C}$		800	mW
... Derating		10	mW/ $^{\circ}\text{C}$
Storage Temperature	-55	+125	$^{\circ}\text{C}$
Operating Temperature	-40	+85	$^{\circ}\text{C}$

Operating Limits

Correct operation of the device outside these limits is not implied.

	Min.	Max.	Units
Supply ($V_{DD} - V_{SS}$)	3.0	5.5	V
Operating Temperature	-40	+85	$^{\circ}\text{C}$
Clock Frequency		10.24	MHz

Operating Characteristics

For the following conditions unless otherwise specified:

 $V_{DD} = 3.3V$ at $T_{amb} = 25^{\circ}C$

Clock Frequency = 10.24MHz

Audio Level 0dB ref. at 1kHz = $(V_{DD} - 1) \times 150\text{vrms}$ e.g. $V_{DD} = 3.3V$ 0dB = 345mVrms

	Notes	Min.	Typ.	Max.	Units
Static Values					
Supply Current		-	2.0	3.0	mA
Input Impedance					
Digital	2	100	-	-	k Ω
Amplifiers	2	1.0	10.0	-	M Ω
Output Impedance (RXOUT, TXOUT)		-	1.0	-	k Ω
Input Logic '1' Voltage	1	70%	-	-	V_{DD}
Input Logic '0' Voltage	1	-	-	30%	V_{DD}
Dynamic Values					
General					
Analog Signal Input Levels		-16.0	-	3	dB
Analog Output Noise	4	-	2.5	5.0	mVrms
Clear Mode					
Passband -3dB Cutoff Frequencies					
Low		-	-	300	Hz
High		3000	-	-	Hz
Passband Ripple (300-3000Hz)					
Rx Channel		0	-	3.6	dB
Tx Channel		0	-	2.9	dB
Passband Ripple (500-2750Hz)					
Rx Channel		0	-	2.2	dB
Tx Channel		0	-	2.0	dB
Filter Attenuation at 3.3kHz					
Rx and Tx Channel		-	30	-	dB
Filter Attenuation at 3.6kHz					
Rx and Tx Channel		-	45	-	dB
Passband Gain (@ 1kHz ref.)					
Rx and Tx Channel		-1.5	-	0.5	dB
Switched-Capacitor Filter Sampling					
Carrier Frequency		-	211.066	-	kHz
		-	3298	-	Hz

	Notes	Min.	Typ.	Max.	Units
Invert Mode Combined Tx and Rx Response					
Passband -3dB Cutoff Frequencies					
Low		-	-	400	Hz
High		2800	-	-	Hz
Passband Gain		-3	-	0.5	dB
Distortion (@ 1kHz)	3	-	1.75	2.75	%
Passband Gain (@ 1kHz ref.)	5	-2.5	-1.5	0	dB
Low Frequency Roll-off (<200Hz)		12	-	-	dB/oct.
Invert Mode Single Channel Response					
Unwanted Modulation Products	3				
Rx and Tx Channel		-	-40	-	dB
Carrier Breakthrough	3				
Rx and Tx Channel		-	-55	-	dB
Baseband Breakthrough	3				
Rx and Tx Channel		-	-40	-	dB

Operating Characteristics Notes:

1. Batch sampled only.
2. By characterisation only.
3. Measured with Input Level 0dB.
4. Short circuit Rx or Tx input, measure noise at corresponding analogue output, in 30kHz bandwidth.
5. Op Amp gain 0dB.
6. Clear mode only.

1.7.2 Package Outlines

The FX128 is available in the package styles outlined below. Mechanical package diagrams and specifications are detailed in Section 10 of this document.

Pin 1 identification marking is shown on the relevant diagram and pins on all package styles number anti-clockwise when viewed from the top.

Handling Precautions

The FX128 is a CMOS LSI circuit which includes input protection. However precautions should be taken to prevent static discharges which may cause damage.

FX128D4 16-pin Plastic S.O.I.C. (DW)

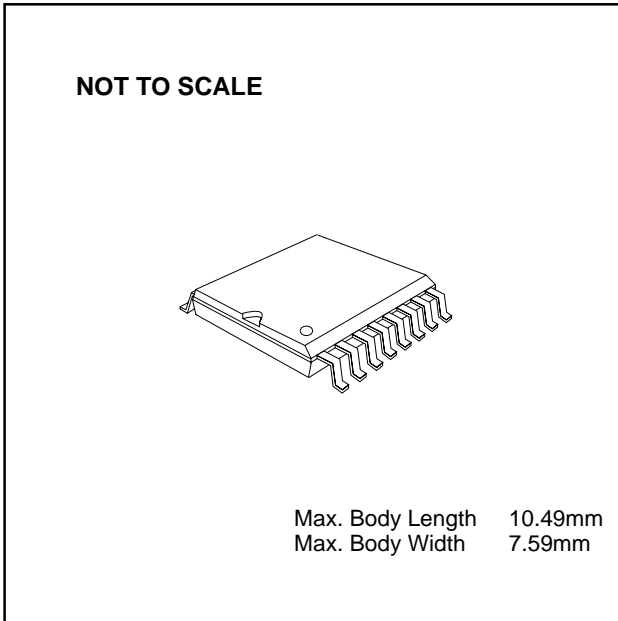

FX128P3 16-pin Plastic DIL (P)

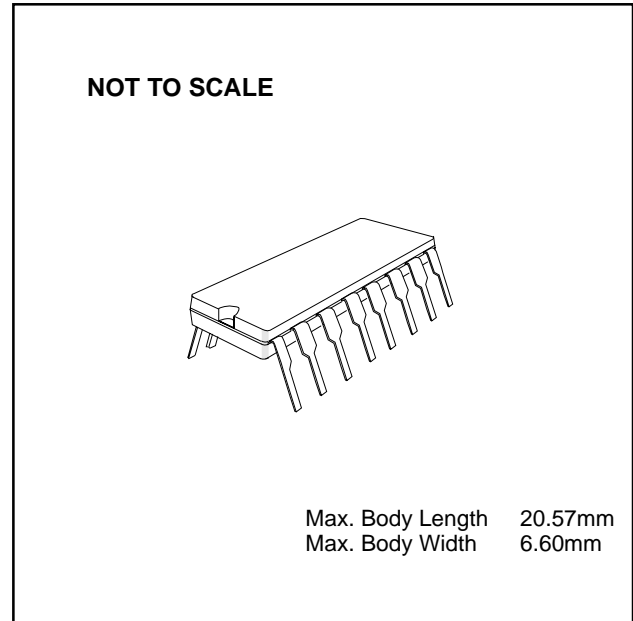

Ordering Information

FX128D4 16-pin Plastic S.O.I.C. (DW)

FX128P3 16-pin Plastic DIL (P)

CML does not assume any responsibility for the use of any circuitry described. No circuit patent licences are implied and CML reserves the right at any time without notice to change the said circuitry.