

CONSUMER MICROCIRCUITS LTD

PRODUCT INFORMATION

**Obsolete Product
- For Information Only -**

PRODUCT INFORMATION



Island Labs

D/254/4 JANUARY 1981

FX 313

FX 323

**QTC DATA
STORE/DISPLAY
DRIVER**

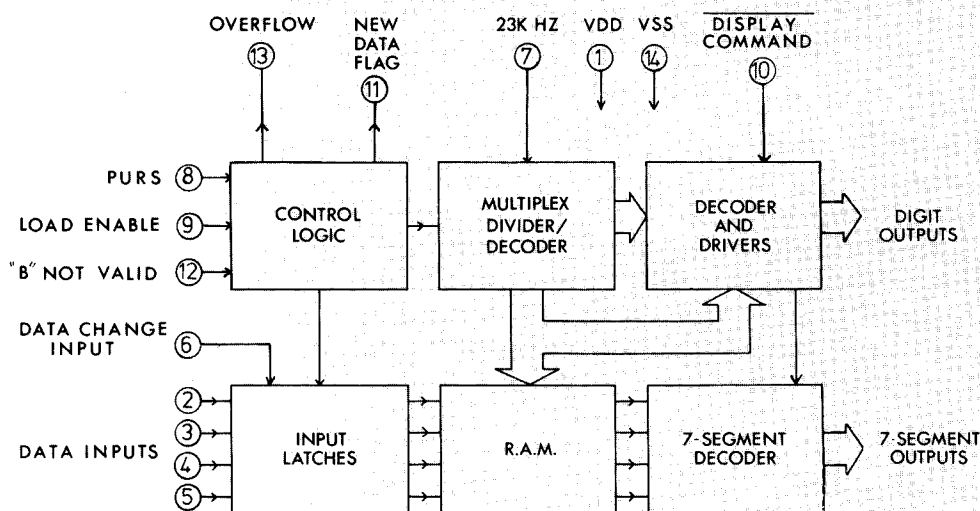

Fig. 1

GENERAL FEATURES

- OUTPUT STORE CONTENTS IN 7-SEGMENT DISPLAY FORMAT
- AUTOMATIC "NO-TONE" LOADING TERMINATION
- INCLUDES OVERLOAD FLAG OUTPUT
- LOW POWER CMOS PROCESS
- FLAGS NEW DATA IN STORE

FEATURES OF THE FX 313

- STORES UP TO 7 QTC CHARACTERS
- DIRECT DRIVE OUTPUTS FOR 1-7 DIGITS LED DISPLAYS

FEATURES OF THE FX 323

- STORES UP TO 16 QTC CHARACTERS
- BINARY CODED DIGIT OUTPUTS FOR UP TO 16 DIGIT DISPLAYS

DESCRIPTION

The FX 313 and FX 323 are used to store address and/or data characters and output multiplex them to a 7 segment display. The FX 313 is dedicated to store and display up to seven characters, and can directly drive a LED display. The FX 323 is suitable for storing and output multiplexing up to sixteen digits. Internal driver transistors interface with the segments (current limiting resistors may be required at higher supply voltages). For 16 digit displays (FX 323), the digit lines are driven by an external decoder. To prevent segment smear on the display from one character to the next the devices incorporate a short blanking period between each digit, i.e. the segment O/Ps are disabled.

Data information is presented in the form of 4 bit QTC coded words at the data inputs. Data is stored in the device's internal register and displayed on command. All numerals 0-9 and four bar symbols (see Fig. 1) can be used to express data, eg. telephone numbers, coded locations of meetings and times etc.

DISPLAY	BLANK	0	1	2	3	4	5	6	7	8	9	-	—			*	NO DISPLAY FUNCTION	
INPUT DATA	D0	X	0	1	0	1	0	1	0	1	0	1	0	1	0	1	0	1
	D1	X	0	0	1	1	0	0	1	1	0	0	1	1	0	0	1	1
	D2	X	0	0	0	0	1	1	1	1	0	0	0	1	1	1	1	1
	D3	X	0	0	0	0	0	0	0	0	1	1	1	1	1	1	1	1
DISPLAY ENABLE	1	0	0	0	0	0	0	0	0	0	0	0	0	0	0	0	0	0

* SEE TEXT

Fig. 2

Character loading is enabled by a 0-1 transition of the LOAD ENABLE pin, which also clears existing store contents and continues until QTC character F is received. (Character F has no display function and represents end of code only). An OVERFLOW indicator will output logical 1 if the number of characters loaded exceeds the capacity of the internal store. The contents of the store are not overwritten in this situation. The OVERFLOW output can drive a single LED or a decimal point of the main display. The OVERFLOW output is reset to logical 0 by the next pulse at the LOAD ENABLE input. On completion of data loading the NEW DATA FLAG is set. This can be used to set an alarm to signal new data in store, eg. the decimal point on the display could be activated.

PURS (Power Up Reset) – Requires Logic 1 (>70% VDD-VSS) for >1 clock cycle after clock is established. The internal circuitry is reset and the data memory is loaded with all 8's as a display test routine.

Operating the DISPLAY COMMAND by a Logic 0 on this input will output the stored characters continuously in multiplexed 7-segment format. The NEW DATA FLAG is reset at the end of the first DISPLAY COMMAND instruction (0-1 change).

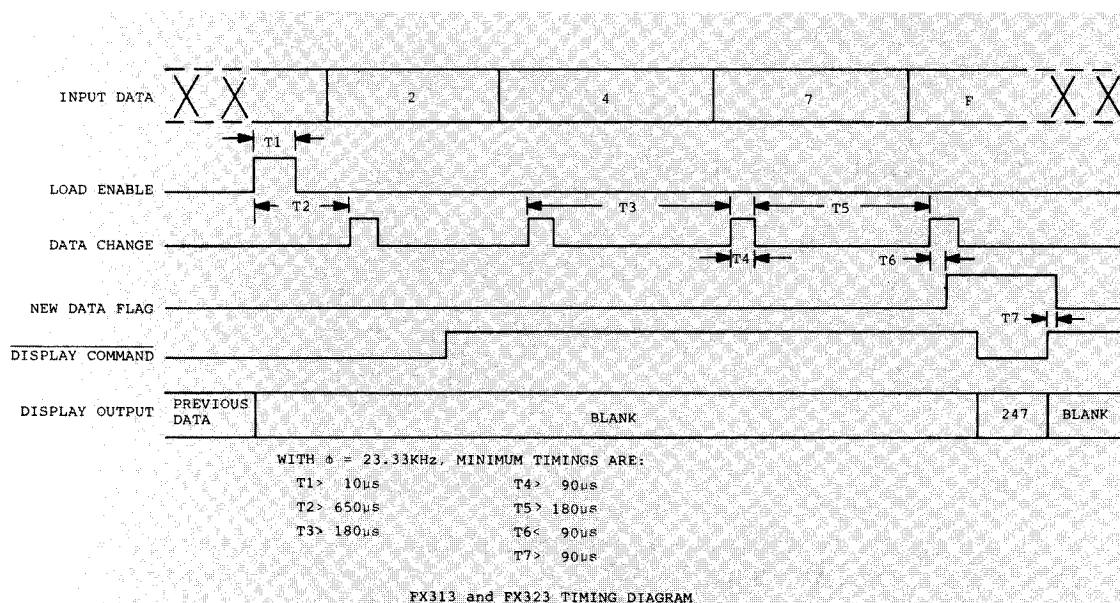

Fig. 3

Character B is pin selectable as no display function or a bar symbol. With B NOT VALID input at Logic 1, B characters are ignored for display purposes; at Logic 0, normal loading continues and the bar symbol is displayed instead. Character B is ignored where B has been added to a data transmission to prevent any possibility of the data aliasing an address code.

Character E is used where successive data digits are identical, and replaces the second identical digit. Therefore if character E is loaded into the data store it is displayed as a repeat of the previous digit.

i.e. data 12888
is transmitted 128E8
and displayed 12888

A clock signal of between 10kHz and 40kHz should be applied to the clock input for dynamic logic and display multiplexing. This signal should be a square wave of VDD-VSS swing (typically 23kHz).

OUTPUT CONFIGURATION

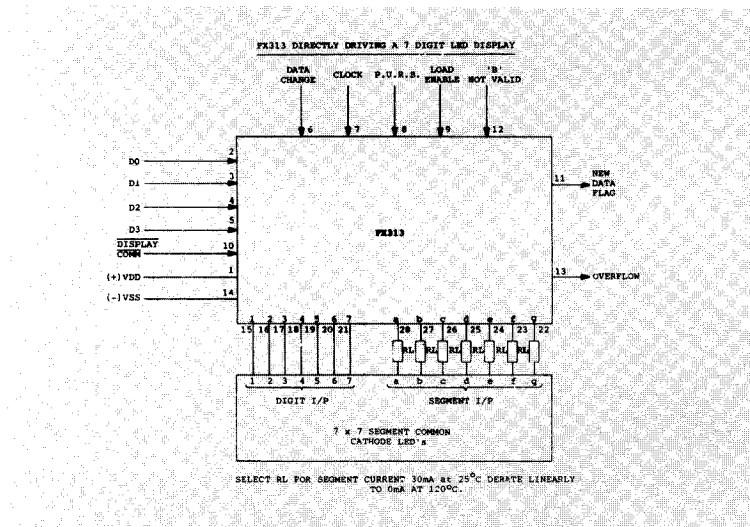

Fig. 4

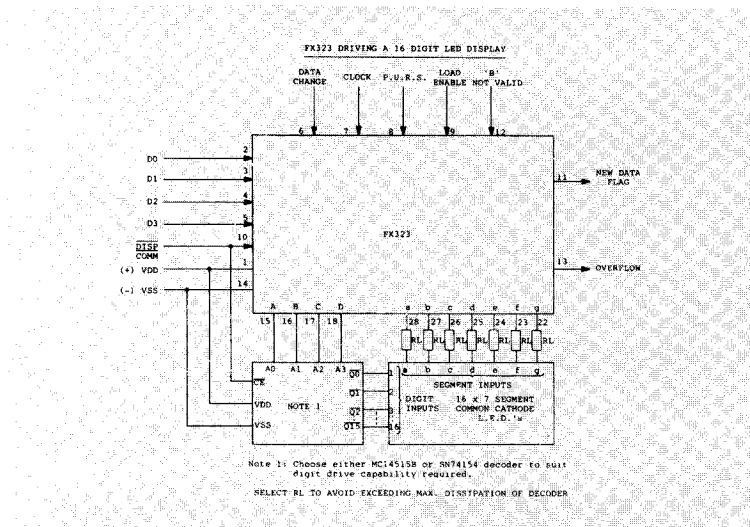

Fig. 5

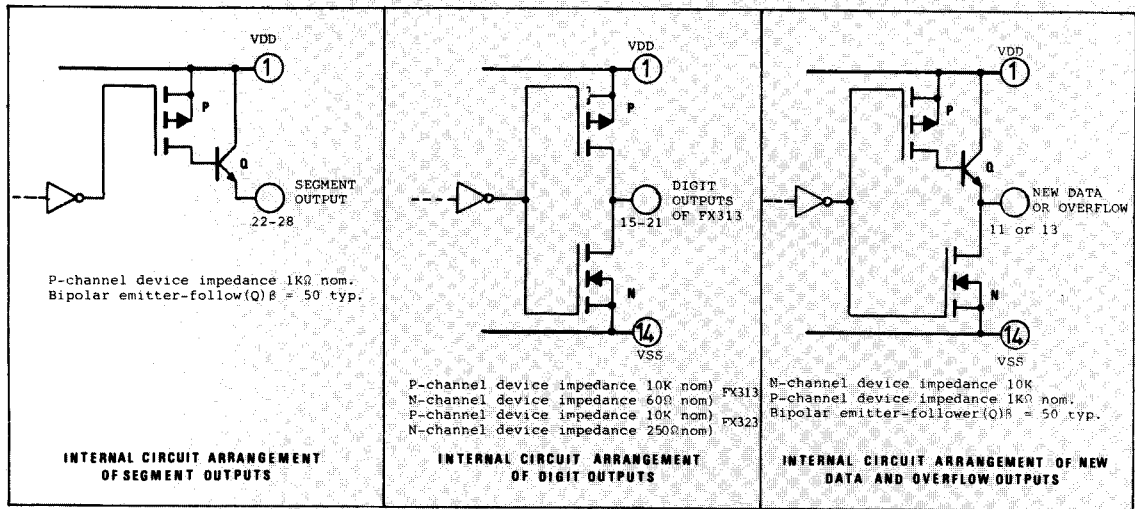

Fig. 6

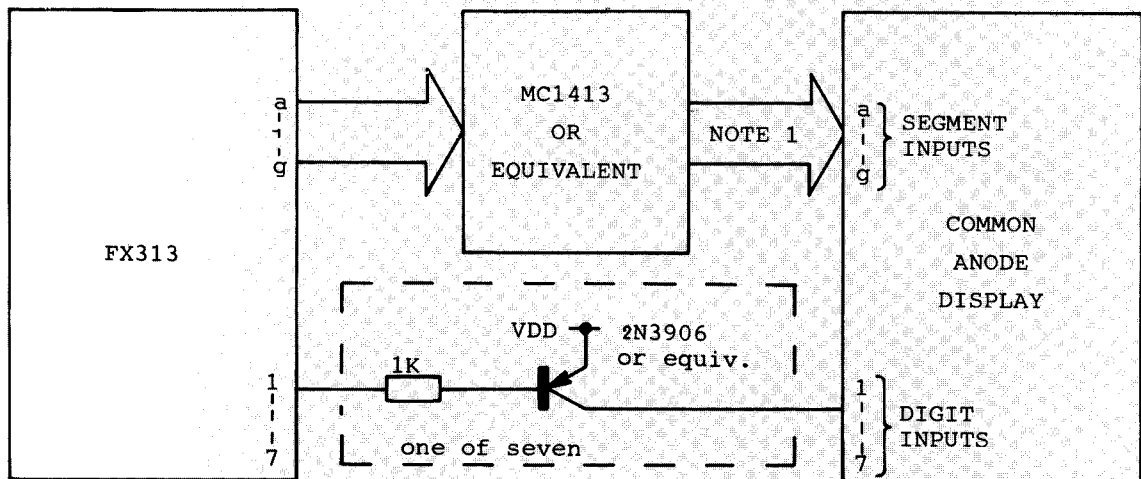

Fig. 7

Fig. 4 shows the FX 313 directly driving a seven digit 7 segment display. Where increased display brightness is required external current drivers are required as illustrated in Fig. 7.

Fig. 5. shows the display multiplex decoding with the FX 323 to drive a display of 16 characters.

Fig. 6 gives the internal configuration of the segment, digit and flag outputs of the FX 313 and FX 323. Parameter values stated are typical values.

ELECTRICAL CHARACTERISTICS

Unless otherwise stated VDD = 5V, clock = 23.33 KHz, TA = 25°C

	CHARACTERISTIC	MIN.	TYP.	MAX.	UNIT	COMMENTS
VDD	Supply Voltage VSS = 0V	4.5	5.0	7.0	V	No loads connected
IDD	Supply Current		50		μA	
VOH	logic '1' output level Isource = 0.1mA	4.0			V	Pins 15-18 FX323 Note 1
VOL	logic '0' output level Isink = 1.6mA			0.8	V	
VIH	logic '1' input level	3.5			V	Pins 2-7, 9, 10 and 12
VIL	logic '0' input level			1.5	V	
	Input level to activate pin 8		3.25		V	Schmitt trigger input
	Input level to deactivate pin 8		1.75		V	
	Multiplex cycle period FX313		4.5		mS	Note 2
	Multiplex cycle period FX323		10.3		mS	
	Output display duration (each digit)		600		μS	
	Interdigit blanking period		43		μS	
φ	Clock frequency input to pin 7	10	23.33	40	KHz	
Pmax	Maximum device dissipation (at 25°C Ambient)			500	mW	
TA	Working temperature range	-30		+85	°C	
Tstg	Storage temperature range	-55		+125	°C	

NOTE 1. i.e. The FX323 can drive one low power TTL load.

NOTE 2. Timings are directly related to input clock frequency.
Values shown are for φ = 23.33 KHz.

PACKAGE DETAILS

FX 313 PIN CONFIGURATION
(TOP VIEW)

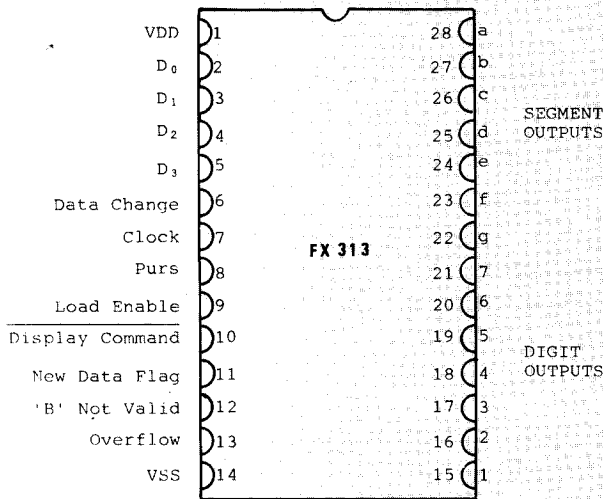

FX 323 PIN CONFIGURATION
(TOP VIEW)

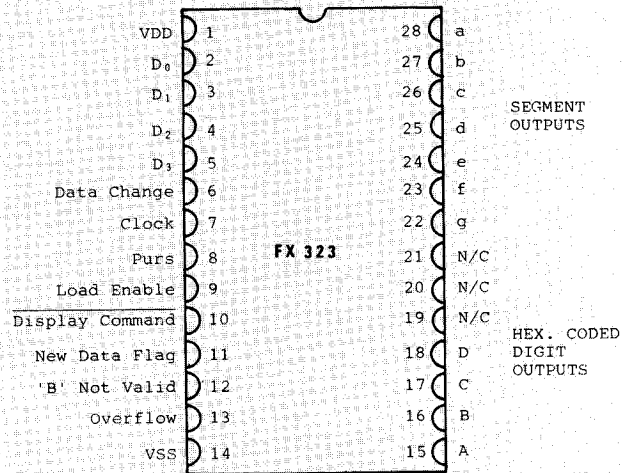

Fig. 8

Fig. 9

The FX 313 and FX 323 are supplied in hermetically sealed ceramic packages.

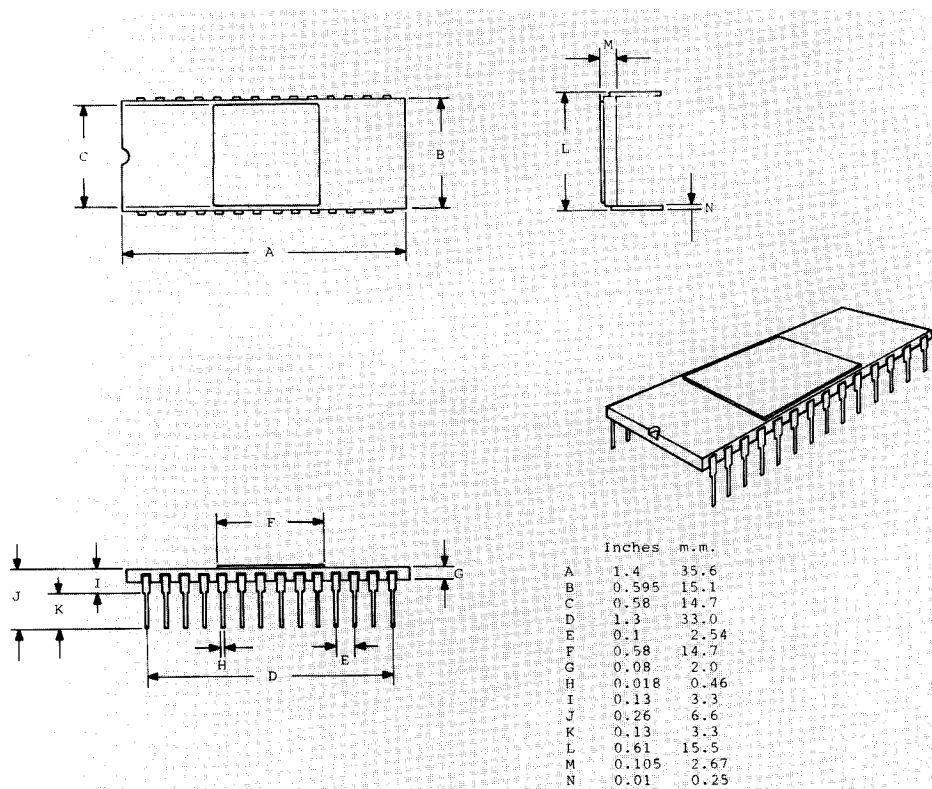

Fig. 10

CML does not assume any responsibility for the use of any circuitry described. No circuit patent licences are implied and CML reserves the right at any time without notice to change said circuitry.