



FX826 AMPS/TACS System Audio Processor

Publication D/826/3 July 1994
Provisional Issue

Features

- Full-Duplex Audio Processing for AMPS & TACS Cellular Systems
- On-Chip Speech and SAT Facilities
 - Tx/Rx Filtering & Gain - SAT Channel
 - Pre-/De-Emphasis - Deviation Limiter -
- Serial μ Processor Interface
- Separate SAT Channel
- "Sidetone" Output Available
- HandsFree Compatibility
- Access to External Processes
 - Compression - Expansion - Signalling
 - VSR Codec (Store/Play) -
- Powersave (Low-Current) Settings

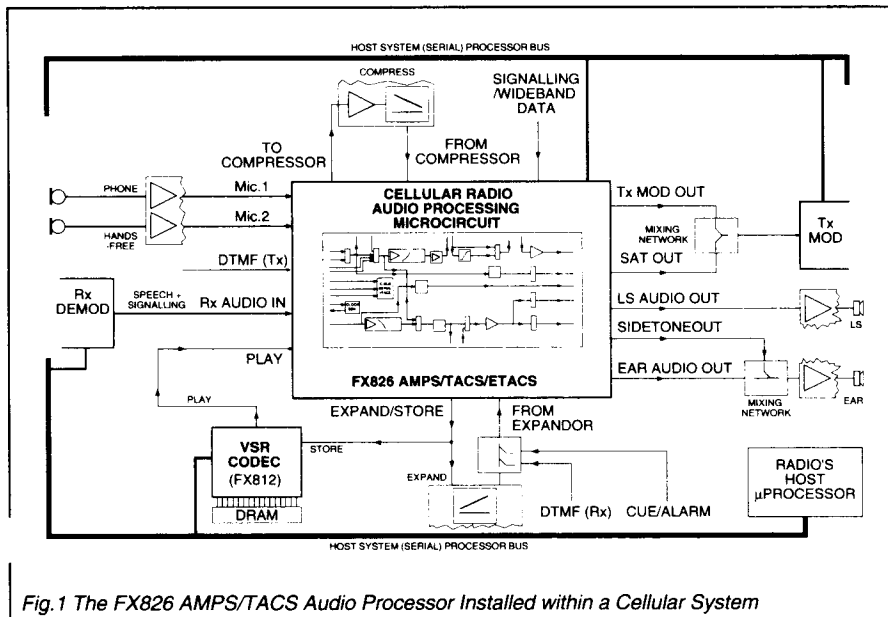

Island Labs

FX826

Brief Description

The FX826 is a μ Processor controlled full-duplex audio processor on a single-chip with separate Tx and Rx paths to provide all the filter/gain/limiting functions necessary to pre-process audio, wideband-data and signalling in cellular communications systems using the AMPS or TACS/ETACS/JTACS specifications.

Selectable inputs available to the transmit path are: a choice of two microphones and DTMF/signalling, with access, in this path, to external compression circuitry. Operationally the Tx path provides input gain/filtering, a deviation limiter and Tx Modulation Drive controls.

In the Rx path the SAT signal is separated from the incoming audio via a filter block and made available at a separate pin for mixing externally with the Tx Modulation Drive.

The Rx path consists of an input gain/filter block for voice, inputs from an external audio expansion system and an output gain control driving either a loudspeaker system or earpiece.

Unique to the FX816/826/836 cellular audio processors is the ability to route audio (Tx or Rx) to an external Voice Store and Retrieve (VSR) device such as the FX802 or FX812 thus providing the radio system with a voice answering and announcement facility using external DRAM.

The FX826, a low-power CMOS device, which reduces the amount of microcircuits and components required in a cellular audio system by providing more functions on a single chip, is available in 28-pin plastic small outline (S.O.I.C.) surface mount and cerdip DIL packages.

Pin Number Function

FX826DW	FX826J	
1	1	Xtal: The output of the on-chip clock oscillator.
2	2	Xtal/Clock: The input to the on-chip clock oscillator. A Xtal or externally derived clock (f_{XTAL}) should be connected here. Note that operation of the FX826 without a suitable Xtal or clock input may cause device damage. See Figure 2 (notes).
3	3	Serial Clock: The "C-BUS" serial data clock input. This clock, produced by the μ Controller, is used for transfer timing of commands and data to the FX826. See Timing Diagrams.
4	4	Command Data: The "C-BUS" serial data input from the μ Controller. Data is loaded to the FX826 in 8-bit bytes, MSB (B7) first, and LSB (B0) last, synchronized to the Serial Clock. See Timing Diagrams.
5	5	Chip Select (\overline{CS}): The "C-BUS" data loading control function. This input is provided by the μ Controller. Data transfer sequences are initiated, completed or aborted by this signal. See Timing Diagrams.
6	6	V_{BIAS}: The internal circuitry bias line, held at $V_{DD}/2$ this pin must be decoupled to V_{SS} . See Figure 2.
7	7	Rx Audio In: Normally taken from the radio's discriminator output, this input has a $1M\Omega$ internal resistor to V_{BIAS} and requires to be connected via a capacitor.
8	8	Expand/Store: A common output that can be used as either an input to an external audio expander or the input to a voice storage medium such as the FX812. Components relevant to the external device requirements should be used at this output. See Figures 2 and 3.
9	9	(Expanded) Audio In: The audio input, via SW5, from an external expander or audio mixing function. This input has a $1M\Omega$ internal resistor to V_{BIAS} and requires to be connected via a capacitor. See Figures 2 and 3.
10	10	Tx Mod Out: The composite Tx audio output to the transmitter modulator from a variable attenuation stage (11 _{μ}). This output is set to V_{BIAS} via an internal $1M\Omega$ resistor when set to Powersave or OFF.
11	11	LS Audio Out: An audio output of the Rx path (or selected audios, see Figure 3) for a loudspeaker system. This is available for handsfree operation. This output can be connected to V_{BIAS} when not required, by SW6 (Configuration Command (10 _{μ})). A driver amplifier may be required.
12	12	Ear Audio Out: An audio output of the Rx path (or selected audios), available as an output for a handset earpiece. This output, in parallel with the LS Audio Out function, can be connected to V_{BIAS} when not required, by SW7 (Configuration Command (10 _{μ})). A driver amplifier may be required.
13	13	Sidetone: A switched "sidetone" from the microphone inputs made available for mixing externally with the "Ear" audio. See Figure 3.
14	14	V_{SS}: Negative supply rail. Signal ground.
<p>Notes on Inputs: To minimize aliasing effects, lowpass filtering may be required at the inputs to this device (especially those supplied from switched-capacitor-type devices) to ensure the input spectrum is kept below 63kHz.</p>		

Pin Number Function

FX826DW FX826J		
15	15	Tx Mix: The output of the Tx Mix Amplifier. Used with external components, it allows the Tx Filter Out output to mix with externally generated signalling tones prior to the final level adjustment.
16	16	SAT Out: The output of the SAT Bandpass filter. This level is recovered from the input Rx audio and is available for mixing externally with the transmitter modulation. See Figure 3.
17	17	Tx Mix In: The input to the Tx Mix Amplifier. Used with external components, it allows the Tx Filter Out output to mix with externally generated signalling tones prior to the final level adjustment. The recovered SAT signal may be introduced at this point. See Figures 2 and 3.
18	18	Tx Filter Out: The output of the Deviation Limiter/Lowpass Filter stage. This stage can be by-passed using SW3 (Configuration Command). See Figure 3.
19	19	No internal connection – Leave open circuit.
20	20	Deviation Limiter In: Input to the on-chip deviation limiter. This input should be a.c. coupled to the Pre-Emphasis Out pin. The a.c. coupling will achieve maximum possible symmetry of limiting as this input has a 1M Ω internal resistor to V _{BIAS} . See Figure 2.
21	21	Pre-Emphasis Out: Audio output from the Tx Gain/Pre-Emphasis function. This output should be a.c. coupled to the Deviation Limiter In pin. See Figures 2 & 3.
22	22	DTMF In: To introduce DTMF type audio, at a suitable level for transmission, to the Tx Path, controlled by SW2 (Configuration Command (10 _u)). This input has an internal 1M Ω resistor to V _{BIAS} and should be connected via a capacitor.
23	23	Compression In: The audio input from an external compression system. This input has an internal 1M Ω resistor to V _{BIAS} and should be connected via a capacitor.
24	24	Compression: The output to an external audio compression system. Currently available compressor/expanders have Op-Amps incorporated. The compressor can be by-passed by SW2.
25	25	Mic.2 In: Tx voice (Mic.) inputs, selectable by SW1 available for handsfree mic./handset mic. or any Tx audio input. Pre-amplification may be required at these inputs. These inputs
26	26	Mic.1 In: each have an internal 1M Ω resistor to V _{BIAS} and should be connected via a capacitor.
27	27	Play In: The input via SW2 from a voice storage device such as the FX812. This "replayed" audio can be sent to Rx or Tx paths allowing a Messaging/Voice Notepad/Answering facility. This input has an internal 1M Ω resistor to V _{BIAS} and should be connected via a capacitor.
28	28	V_{DD}: Positive supply rail. A single +5-volt power supply is required. Levels and voltages within this Audio Processor are dependent upon this supply.
<p><i>"C-BUS" is CML's proprietary standard for the transmission of commands and data between a μController and the relevant Cellular microcircuits. It may be used with any μController, and can, if desired, take advantage of the hardware serial I/O functions embodied into many types of μController. The "C-BUS" data rate is determined solely by the μController. For further details refer to CML Publication No. DμINT/1 June 1991.</i></p>		

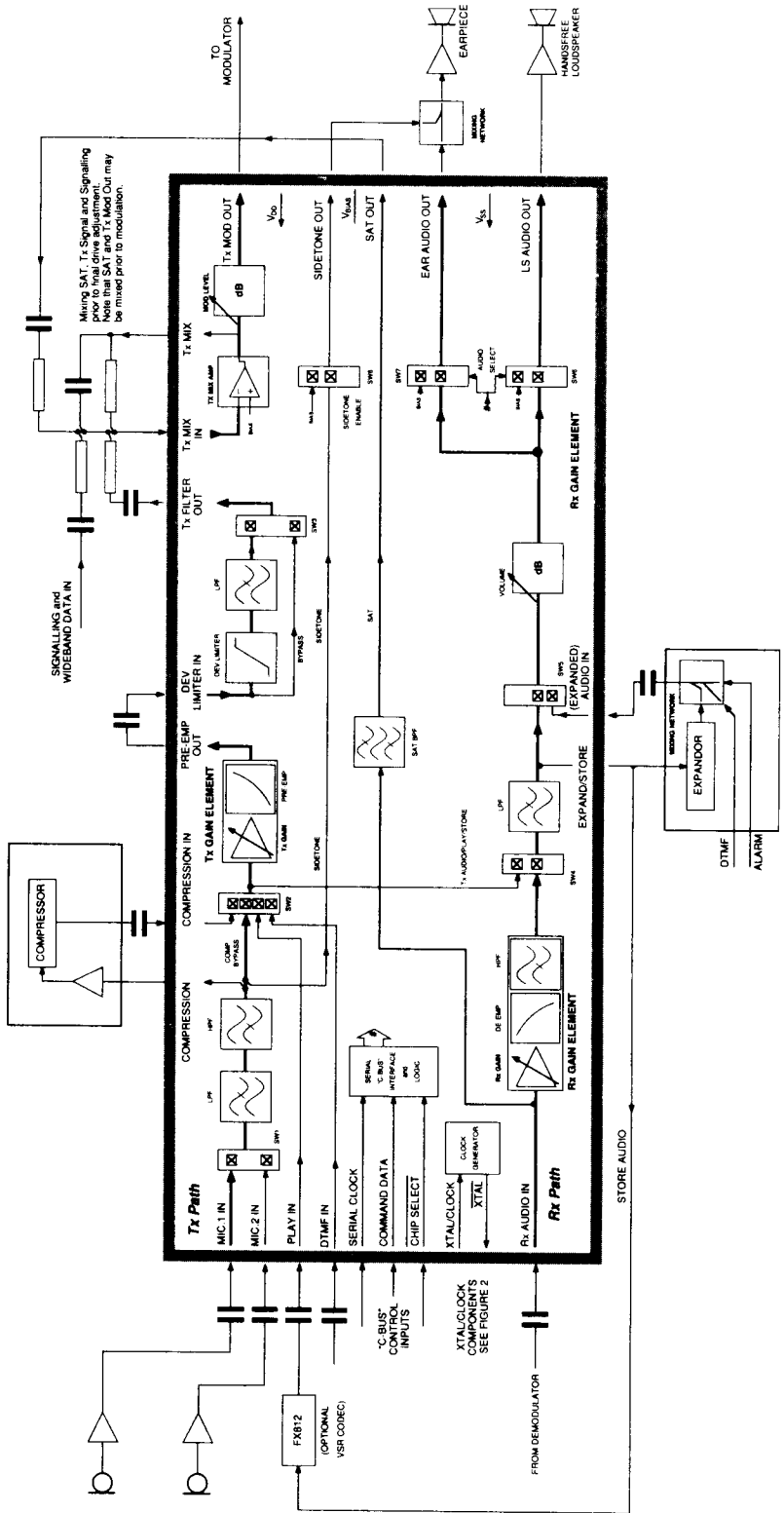

Fig.3 The FX826 Internal and External Signal Paths within a TACS Cellular Radio System

The Controlling System

"C-BUS" Hardware Interface

"C-BUS" is CML's proprietary standard for the transmission of commands and data between a μ Controller and CML's New Generation microcircuits.

"C-BUS" has been designed for a low IC pin-count, flexibility in handling variable amounts of data, and simplicity of system design and μ Controller software.

It may be used with any μ Controller, and can, if desired, take advantage of the hardware serial I/O functions built into many types of μ Controller. Because of this flexibility and because the BUS data-rate is determined solely by the μ Controller, the system designer has complete freedom to choose a μ Controller appropriate to the overall system processing requirements.

Control of the functions and levels within the FX826 AMPS and TACS Audio Processor is by a group of Address/Commands and appended data instructions from the system μ Controller to set/adjust the functions and elements of the device. The use of these instructions is detailed in the following paragraphs and tables.

Command Assignment	Address/Command (A/C) Byte				Command Data	Table
	Hex	MSB	Binary	LSB		
General Reset	01	0 0 0 0	0 0 0 1	0 1		
Configuration Command	10	0 0 0 1	0 0 0 0	0 0	+	1 byte
Tx Gain & Mod. Command	11	0 0 0 1	0 0 0 1	0 1	+	1 byte
Rx Gain & Vol. Command	12	0 0 0 1	0 0 1 0	1 0	+	1 byte
Powersave Command	13	0 0 0 1	0 0 1 1	1 1	+	1 byte

Table 1 "C-Bus" Address/Commands

In "C-BUS" protocol the audio processor is allocated Address/Command (A/C) values 10_H to 13_H. Configuration, Tx/Rx Gains and Powersave assignments and data requirements are given in Table 1. Each instruction consists of an Address/Command (A/C) byte followed by a data instruction formulated from the following tables.

Commands and Data are only to be loaded in the group

configurations detailed, as the "C-BUS" interface recognises the first byte after Chip Select (logic "0") as an Address/Command. Function or Level control data, which is detailed in Tables 2, 3, 4 and 5, is acted upon at the end of the loaded instruction. See Timing Diagrams Figures 5 and 6.

Upon Power-Up the value of the "bits" in this device will be random (either "0" or "1"). A **General Reset Command (01_H)** will be required to set all FX826 registers to 00_H.

Configuration Command (Preceded by A/C 10_H)

Setting	Control Bits
MSB	Transmitted First
Bit 7	Sw8 Sidetone
0	Sidetone Bias
1	Sidetone Enabled
6	Sw6/7 Rx Audio
0	Ear Enabled, LS Bias
1	LS Enabled, Ear Bias
5	Sw5 Expander
0	Expander By-Pass
1	Expander Route
4	Sw4 Tx/Rx Audio
0	Tx Store/Audio
1	Rx Store/Audio
3	Sw3 Dev. Limiter
0	Dev. Limiter By-Pass
1	Dev. Limiter Route
2	Sw1 Mic. Inputs
0	Mic. 1 Input
1	Mic. 2 Input
1	Sw2 Tx Function
0	DTMF In
0	Compressor By-Pass
1	Compressor In
1	Play In

Table 2 Configuration Commands

Tx Gain & Mod. Command (Preceded by A/C 11_H)

Setting	Gain (dBs)
MSB	Transmitted First
7 6 5 4	Tx Mod. Level
0 0 0 0	OFF (Low Z to V _{BIAS})
0 0 0 1	-5.6
0 0 1 0	-5.2
0 0 1 1	-4.8
0 1 0 0	-4.4
0 1 0 1	-4.0
0 1 1 0	-3.6
0 1 1 1	-3.2
1 0 0 0	-2.8
1 0 0 1	-2.4
1 0 1 0	-2.0
1 0 1 1	-1.6
1 1 0 0	-1.2
1 1 0 1	-0.8
1 1 1 0	-0.4
1 1 1 1	0
3 2 1 0	Tx Input Gain
0 0 0 0	-2.65
0 0 0 1	-2.05
0 0 1 0	-1.50
0 0 1 1	-0.95
0 1 0 0	-0.45
0 1 0 1	0
0 1 1 0	0.45
0 1 1 1	0.85
1 0 0 0	1.25
1 0 0 1	1.65
1 0 1 0	2.05
1 0 1 1	2.40
1 1 0 0	2.70
1 1 0 1	3.05
1 1 1 0	3.35
1 1 1 1	3.65

Table 3 Tx Gain & Mod. Commands

The Controlling System

Rx Gain & Vol. Command (Preceded by A/C 12,)

Setting				Gain (dBs)
MSB				Transmitted First Rx Volume OFF (Low Z to V _{BIAS})
7	6	5	4	
0	0	0	0	
0	0	0	1	
0	0	1	0	
0	0	1	1	
0	1	0	0	
0	1	0	1	
0	1	1	0	
0	1	1	1	
1	0	0	0	
1	0	0	1	
1	0	1	0	
1	0	1	1	
1	1	0	0	
1	1	0	1	
1	1	1	0	
1	1	1	1	
3				Rx Input Gain
0	0	0	0	
0	0	0	1	
0	0	1	0	
0	0	1	1	
0	1	0	0	
0	1	0	1	
0	1	1	0	
0	1	1	1	
1	0	0	0	
1	0	0	1	
1	0	1	0	
1	0	1	1	
1	1	0	0	
1	1	0	1	
1	1	1	0	
1	1	1	1	

Table 4 Rx Gain and Vol. Commands

Powersave Command (Preceded by A/C 13,)

Setting							Control Bits
MSB							Transmitted First All must be a logic "0"
Bit 7							
7	6	5	4	3	2	1	
0	0	0	0	0	0	0	
0							
0							
1							
1							
Powersave Setting							Powersave FX826 Enable FX826
0							

Table 5 Powersave Command

Reference Signal Levels

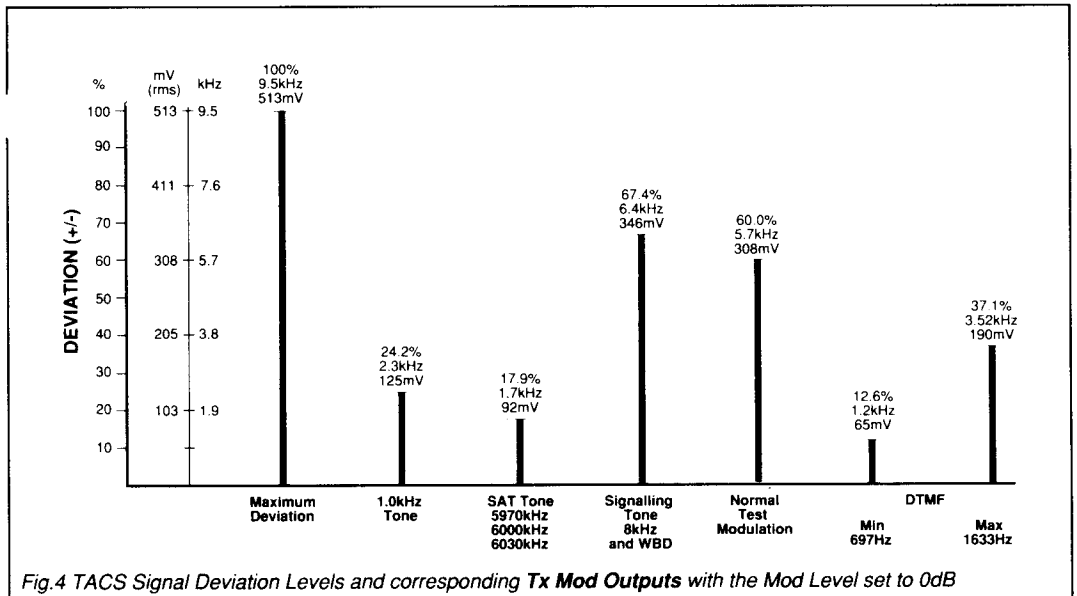

Fig.4 TACS Signal Deviation Levels and corresponding Tx Mod Outputs with the Mod Level set to 0dB

Control Timing Information

Timing Specification – Figures 5 and 6.

Characteristics	See Note	Min.	Typ.	Max.	Unit
t_{CSE}	"CS-Enable to Clock-High"	1	2.0	–	μs
t_{CSH}	Last "Clock-High to CS-High"	1	4.0	–	μs
t_{CSOFF}	"CS-High" Time between transactions	1, 2	2.0	–	μs
t_{CK}	"Clock-Cycle" Time	1	2.0	–	μs
t_{NXT}	"Inter-Byte" Time	1	4.0	–	μs
t_{CH}	"Serial Clock-High" Period	500	–	–	ns
t_{CL}	"Serial Clock-Low" Period	500	–	–	ns
t_{CDS}	"Command Data Set-Up" Time	250	–	–	ns
t_{CDH}	"Command Data Hold" Time	0	–	–	ns

Notes

1. These Minimum Timing values are altered during operation of the FX812 VSR Codec.
2. Chip Select must be taken to a logic "1" between each individual transaction.

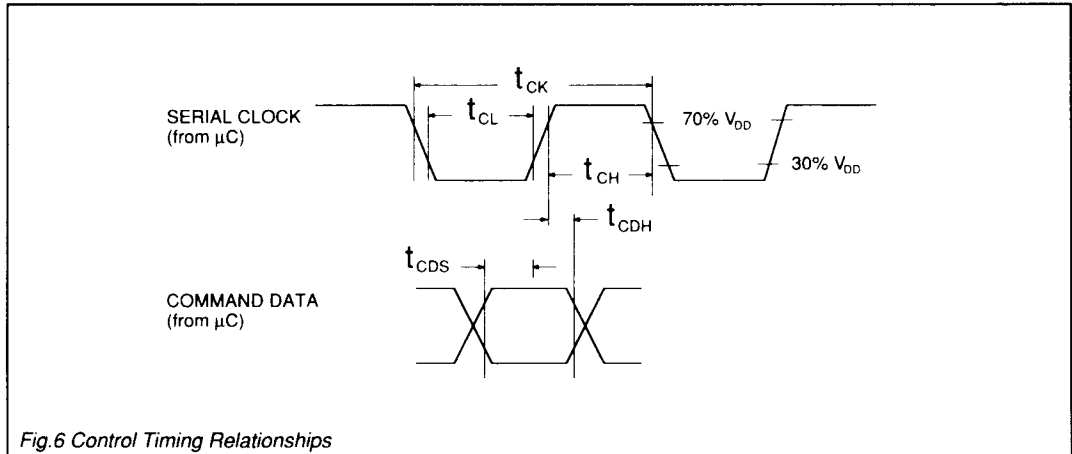
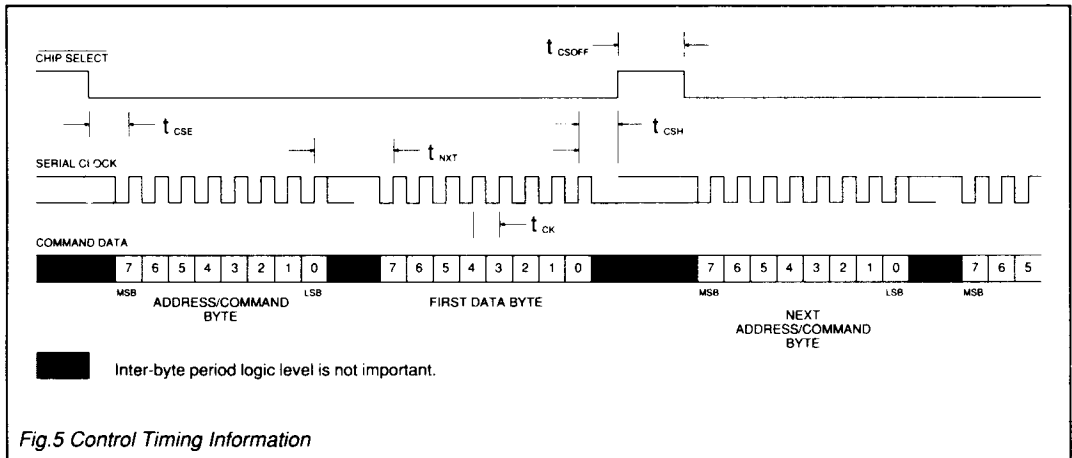

Frequency Responses

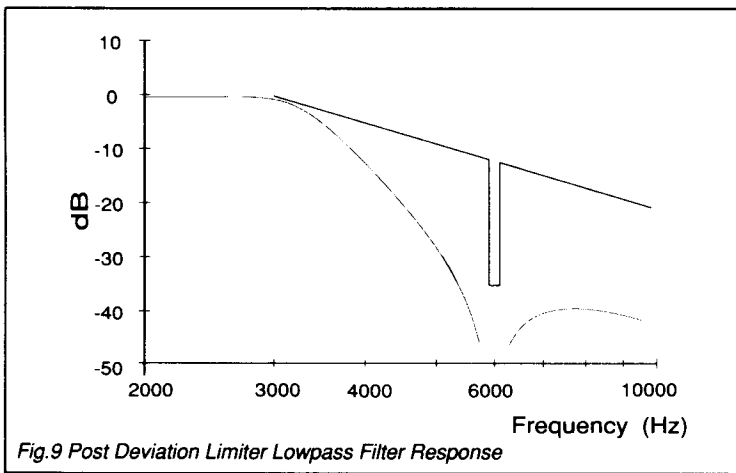
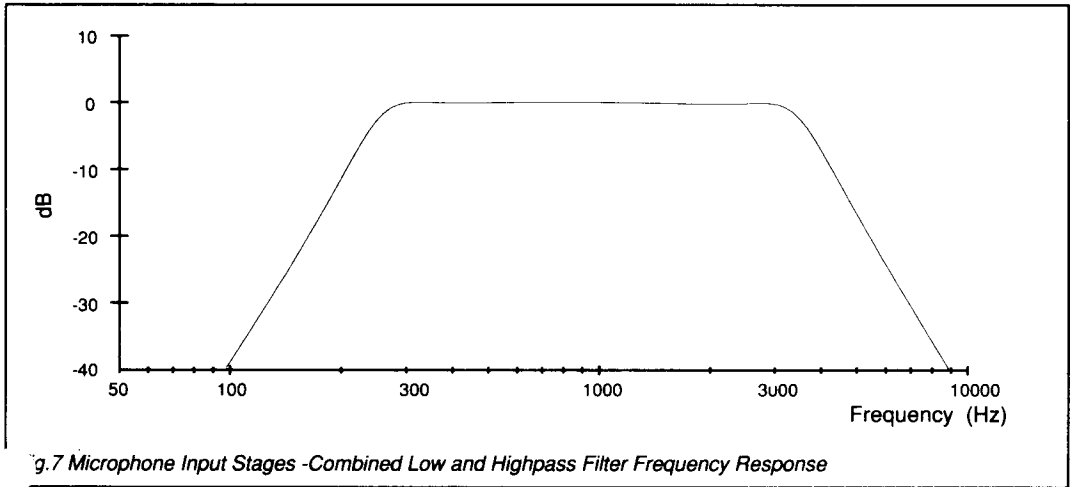
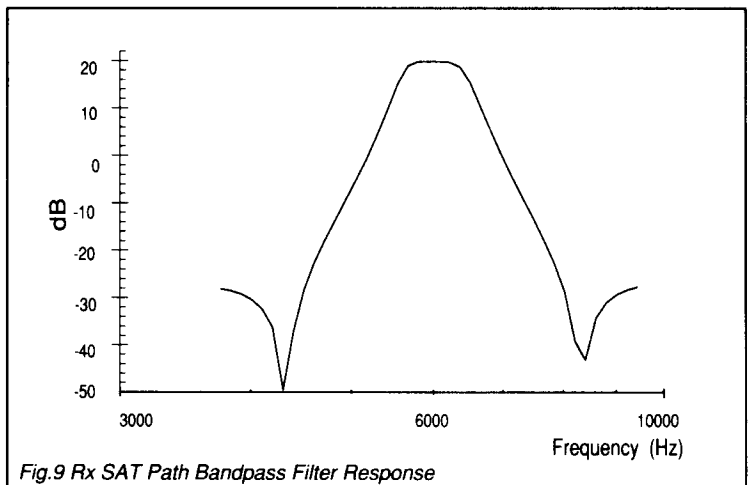

Figure 7
Mic.1/2 In to Compression Out
 $V_{DD} = 5.0V$
 Signal Input Level = 55.0mVrms

Figure 8
Dev Limiter In to Tx Filter Out
 $V_{DD} = 5.0V$
 Signal Input Level = 55.0mVrms

Figure 9
Rx Audio In to SAT out
 $V_{DD} = 5.0V$
 Signal Input Level = 100mVrms



Specification

Absolute Maximum Ratings

Exceeding the maximum rating can result in device damage. Operation of the device outside the operating limits is not implied.

Supply voltage		-0.3 to 7.0V
Input voltage at any pin (ref. $V_{SS} = 0V$)		-0.3 to ($V_{DD} + 0.3V$)
Sink/source current (supply pins)		+/- 30mA
(other pins)		+/- 20mA
Total device dissipation @ $T_{AMB} = 25^{\circ}C$		800mW Max.
Derating		10mW/ $^{\circ}C$
Operating temperature range:	FX826DW	-40 $^{\circ}C$ to +85 $^{\circ}C$ (plastic)
	FX826J	-40 $^{\circ}C$ to +85 $^{\circ}C$ (cerdip)
Storage temperature range:	FX826DW	-40 $^{\circ}C$ to +85 $^{\circ}C$ (plastic)
	FX826J	-55 $^{\circ}C$ to +125 $^{\circ}C$ (cerdip)

Operating Limits

All device characteristics are measured under the following conditions unless otherwise specified:

$V_{DD} = 5.0V$. $T_{AMB} = 25^{\circ}C$. Xtal/Clock $f_0 = 4.000MHz$. Audio level 0dB ref. = 308mV rms @ 1.0kHz.

Characteristics	See Note	Min.	Typ.	Max.	Unit
Static Values					
Supply Voltage		4.5	5.0	5.5	V
Supply Current					
Operating		–	6.5	–	mA
Powersave		–	0.5	–	mA
Alias Frequency		–	63.0	–	kHz
On-Chip Xtal Oscillator					
R_{IN}		10.0	–	–	M Ω
R_{OUT}		–	10.0	–	k Ω
Inverter d.c. Voltage Gain		–	10.0	–	V/V
Gain/Bandwidth Product		–	10.0	–	MHz
Tx Mix Amp (Open Loop Gain)		–	50.0	–	dB
(Bandwidth)		20.0	–	–	kHz
Analogue Input Impedances					
Mic. 1 & 2		–	500	–	k Ω
Play		–	500	–	k Ω
Comp In		–	500	–	k Ω
DTMF In		–	500	–	k Ω
Dev. Limiter In		–	100	–	k Ω
(Expanded) Audio In		–	47.0	–	k Ω
Tx Mix In		10.0	–	–	M Ω
Rx Audio In		–	100	–	k Ω
Analogue Output Impedances					
Pre-Emp Out		–	600	–	Ω
Tx Mod Out		–	600	–	Ω
Expand/Store		–	600	–	Ω
LS and Ear Audio		–	1.0	–	k Ω
SAT Out	3	–	1.0	–	k Ω
Tx Filter Out		–	600	–	Ω
Comp Out		–	600	–	Ω
Sidetone Out		–	2.0	–	k Ω
Tx Mix (Open Loop)		–	6.0	–	k Ω
(Closed Loop)		–	600	–	Ω
Switches – ON		–	1.0	–	k Ω
– OFF		10.0	–	–	M Ω
Control Interface Parameters					
Input Logic Levels					
Logic "1"	1	3.5	–	–	V
Logic "0"	1	–	–	1.5	V
I_{IN} (logic "1" or "0")	1	-1.0	–	1.0	μA
Input Capacitance	1	–	–	7.5	pF
Channel Performances					
Tx Path					
Filter Specifications					
Pre-Compression L/HPF Combination					
Passband		300		3000	Hz
Slope - below 300Hz		+24.0	–	–	dB/oct.
above 3000Hz		-24.0	–	–	dB/oct.
Tx Gain Pre-Emphasis					
Gain at 1.0kHz		–	0	–	dB
Slope (300Hz - 3000Hz)		–	6.0	–	dB/oct.

Package Outlines

The FX826 is available in the package styles outlined below. Mechanical package diagrams and specifications are detailed in Section 10 of this document. Pin 1 identification marking is shown on the relevant diagram and pins on all package styles number anti-clockwise when viewed from the top.

Handling Precautions

The FX826 is a CMOS LSI circuit which includes input protection. However precautions should be taken to prevent static discharges which may cause damage.

FX826DW 28-pin plastic S.O.I.C. (D1)

FX826J 28-pin cerdip DIL (J5)

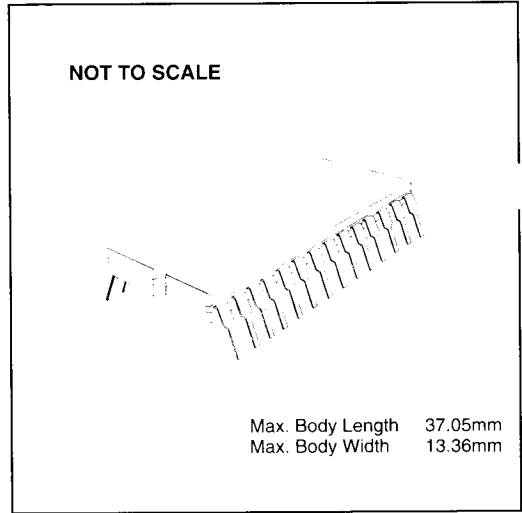
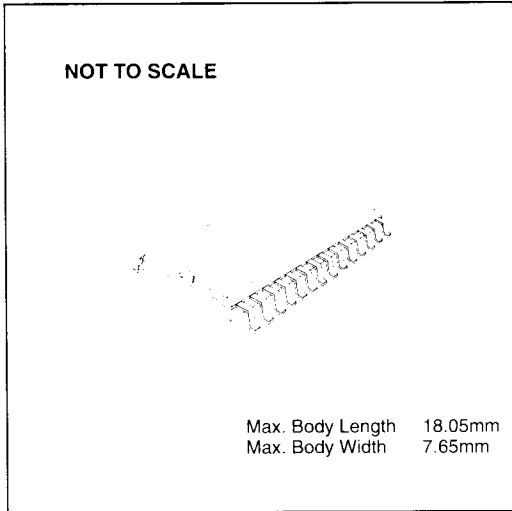

Ordering Information

FX826DW 28-pin plastic S.O.I.C. (D1)

FX826J 28-pin cerdip DIL (J5)



CML Microcircuits

COMMUNICATION SEMICONDUCTORS

CML Product Data

In the process of creating a more global image, the three standard product semiconductor companies of CML Microsystems Plc (*Consumer Microcircuits Limited (UK)*, *MX-COM, Inc (USA)* and *CML Microcircuits (Singapore) Pte Ltd*) have undergone name changes and, whilst maintaining their separate new names (*CML Microcircuits (UK) Ltd*, *CML Microcircuits (USA) Inc* and *CML Microcircuits (Singapore) Pte Ltd*), now operate under the single title **CML Microcircuits**.

These companies are all 100% owned operating companies of the CML Microsystems Plc Group and these changes are purely changes of name and do not change any underlying legal entities and hence will have no effect on any agreements or contacts currently in force.

CML Microcircuits Product Prefix Codes

Until the latter part of 1996, the differentiator between products manufactured and sold from MXCOM, Inc. and Consumer Microcircuits Limited were denoted by the prefixes MX and FX respectively. These products use the same silicon etc. and today still carry the same prefixes. In the latter part of 1996, both companies adopted the common prefix: CMX.

This notification is relevant product information to which it is attached.

Company contact information is as below:



**CML Microcircuits
(UK) Ltd**

COMMUNICATION SEMICONDUCTORS

Oval Park, Langford, Maldon,
Essex, CM9 6WG, England
Tel: +44 (0)1621 875500
Fax: +44 (0)1621 875600
uk.sales@cmlmicro.com
www.cmlmicro.com



**CML Microcircuits
(USA) Inc.**

COMMUNICATION SEMICONDUCTORS

4800 Bethania Station Road,
Winston-Salem, NC 27105, USA
Tel: +1 336 744 5050,
0800 638 5577
Fax: +1 336 744 5054
us.sales@cmlmicro.com
www.cmlmicro.com



**CML Microcircuits
(Singapore) Pte Ltd**

COMMUNICATION SEMICONDUCTORS

No 2 Kallang Pudding Road, 09-05/
06 Mactech Industrial Building,
Singapore 349307
Tel: +65 7450426
Fax: +65 7452917
sg.sales@cmlmicro.com
www.cmlmicro.com